

BP12200D

12V 200Ah(20hr)

The rechargeable batteries are lead-lead dioxide systems. The dilute sulfuric acid electrolyte is absorbed by separators and plates and thus immobilized. Should the battery be accidentally overcharged producing hydrogen and oxygen, special one-way valves allow the gases to escape thus avoiding excessive pressure build-up. Otherwise, the battery is completely sealed and is, therefore, maintenance-free, leak proof and usable in any position.

Battery Construction

Component	Positive plate	Negative plate	Container	Cover	Safety valve	Terminal	Separator	Electrolyte
Raw material	Lead dioxide	Lead	ABS	ABS	Rubber	Copper	Fiberglass	Sulfuric acid

General Features

- Absorbent Glass Mat (AGM) technology for efficient gas recombination of up to 99% and freedom from electrolyte maintenance or water adding.
- Not restricted for air transport-complies with IATA/ICAO Special Provision A67.
- UL-recognized component.
- Can be mounted in any orientation.
- Computer designed lead, calcium tin alloy grid for high power density.
- Long service life, float or cyclic applications.
- Maintenance-free operation.
- Low self discharge.

Dimensions and Weight

Length(mm / inch)	522/20.55
Width(mm / inch)	238/9.37
Height(mm / inch)	218/8.58
Total Height(mm / inch)	223/8.78
Approx. Weight(Kg / lbs)	60/132.28

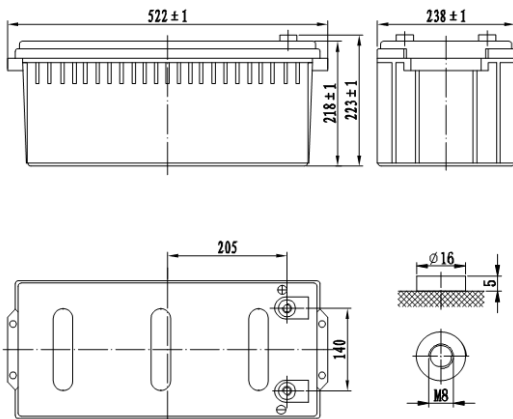

Performance Characteristics

Nominal Voltage	12V
Number of cell	6
Design Life	10 years
Nominal Capacity 77°F(25°C)	
20 hour rate (20.0A, 10.8V)	200Ah
10 hour rate (18.7A, 10.8V)	187Ah
1 hour rate (126A, 9.6V)	126Ah
Internal Resistance	
Fully Charged battery 77°F(25°C)	≤ 4.0mOhms
Self-Discharge	
3% of capacity declined per month at 25 °C (average)	
Operating Temperature Range	
Discharge	-20~60°C
Charge	-10~55°C
Storage	-10~50°C
Max. Discharge Current 77°F(25°C)	1000A(5s)
Short Circuit Current	3300A
Charge Methods: Constant Voltage Charge 77° F(25 °C)	
Cycle use	2.40-2.45VPC
Maximum charging current	60A
Temperature compensation	-30mV/°C
Standby use	2.20-2.30VPC
Temperature compensation	-20mV/°C

Discharge Constant Current (Amperes at 77 °F25 °C)

End Point Volts/Cell	15min	30min	45min	1h	3h	5h	10h	20h
1.60V	350	215	156	126	57.0	38.0	19.1	10.80
1.65V	340	207	150	122	55.0	37.0	19.0	10.60
1.70V	327	201	146	118	54.5	36.4	18.9	10.40
1.75V	310	195	142	115	52.9	35.8	18.8	10.20
1.80V	261	182	137	112	50.5	35.2	18.7	10.00

Discharge Constant Power (Watts at 77 ° F25 °C)

End Point Volts/Cell	15min	30min	45min	1h	2h	3h	5h
1.60V	607	392	288	227	137	108	72.6
1.65V	586	380	280	222	135	106	71.6
1.70V	569	373	274	218	132	104	70.8
1.75V	561	363	269	214	128	100	69.9
1.80V	538	355	265	212	125	97.0	69.0

(Note)The above characteristics data are average values obtained within three charge/discharge cycles not the minimum values.

BP12200D

12V 200Ah(20hr)

